



OVERVIEW

The Valveworks USA FM4 Series consists of a lineup of gate valves with reliable, proven designs that are engineered and manufactured to meet the requirements of 6A, and where a 7 1/16" bore is required. This series of gate valves offer the user several options depending on the specific application including achieving a positive seal at wellbore/flowline pressures ranging from zero to 5,000 PSI.

FM4 Series gate valves are full bore valves. This allows for downhole tools to be passed through the wellhead and / or Christmas tree and reduces turbulent flow. FM4 Series valves are similar to each other in design with only slight variations across the lineup, offering a high percentage of parts interchangeability, giving you an efficiency-driven advantage in the management and maintenance of your gate valve fleet, and providing optimal life cycle management integrity.

This brochure provides an in-depth look at the details of this series of gate valves and explains the features, benefits, characteristics, dimensional & technical data, and other valuable information needed to determine which valve provides an optimal solution for your specific application.

TABLE 1 - PRODUCT FEATURES

	MODEL FM4	MODEL FM4 SG	MODEL FM4 RC	MODEL FM4 RC SG	MODEL FM4 BSOP ^f	MODEL FM4 RC BSOP ^f
FLOW DIRECTION	UNIDIRECTIONAL ^a	BIDIRECTIONAL	UNIDIRECTIONAL ^a	BIDIRECTIONAL	BIDIRECTIONAL	BIDIRECTIONAL
AVAILABLE BORE SIZES^b & RATED WORKING PRESSURES (psi)	7 1/16" 2K, 3K, 5K	7 1/16" 2K, 3K, 5K	7 1/16" 2K, 3K, 5K	7 1/16" 2K, 3K, 5K	7 1/16" 3K, 5K	7 1/16" 3K, 5K
AVAILABLE PSL^c	1, 2	1, 2	1, 2, 3, 3G	1, 2, 3, 3G	1, 2	1, 2, 3, 3G
MATERIAL CLASSES	AA, BB, CC, DD, EE, FF	AA, BB, CC, DD, EE, FF	AA, BB, CC, DD, EE, FF	AA, BB, CC, DD, EE, FF	AA, BB, CC, DD, EE, FF	AA, BB, CC, DD, EE, FF
VALVE BODY	CAST	CAST	FORGED	FORGED	CAST	FORGED
GATE TYPE	EXPANDING ^d	SLAB	EXPANDING ^d	SLAB	SLAB	SLAB
SEALING ACTION	MECHANICAL	PRESSURE ENERGIZED	MECHANICAL	PRESSURE ENERGIZED	PRESSURE ENERGIZED	PRESSURE ENERGIZED
OPERATION	MANUAL ^e	MANUAL ^e	MANUAL ^e	MANUAL ^e	MANUAL ^f	MANUAL ^f
BORE TYPE	FULL-BORE	FULL-BORE	FULL-BORE	FULL-BORE	FULL-BORE	FULL-BORE
GATE / SEAT SEAL	METAL TO METAL	METAL TO METAL	METAL TO METAL	METAL TO METAL	METAL TO METAL	METAL TO METAL
STEM TYPE	NON-RISING	NON-RISING	NON-RISING	NON-RISING	RISING	RISING
STEM PACKING TYPE	OPTI-SEAL	OPTI-SEAL	OPTI-SEAL	OPTI-SEAL	OPTI-SEAL	OPTI-SEAL
REPACKING	YES ^g	YES ^g	YES ^g	YES ^g	YES ^h	YES ^h
BEARINGS	2 ⁱ	2 ⁱ	2 ⁱ	2 ⁱ	3 ⁱ	3 ⁱ
BODY LUBRICATION FITTINGS	2	2	2	2	2	2
BODY / BONNET CONNECTION	BOLTED	BOLTED	BOLTED	BOLTED	BOLTED	BOLTED
BALANCE STEM	NO	NO	NO	NO	YES	YES
END CONNECTIONS	FLANGED (RTJ)	FLANGED (RTJ)	FLANGED (RTJ)	FLANGED (RTJ)	FLANGED (RTJ)	FLANGED (RTJ)
TEMPERATURE RANGE	-75°F (-60°C) THRU 250°F (121°C)	-75°F (-60°C) THRU 250°F (121°C)	-75°F (-60°C) THRU 250°F (121°C)	-75°F (-60°C) THRU 250°F (121°C)	-75°F (-60°C) THRU 250°F (121°C)	-75°F (-60°C) THRU 250°F (121°C)

a) Equipped with a non-sealing seat on the upstream side. See engineering note titled "Model FM4 & Model FM4 RC" for details.
 b) 7-1/16" X 5-1/8", 7-1/16" X 6", 7-1/16" X 6-1/8", 7-1/16" X 6-3/8", 7-1/16" X 6-5/8", and 7-1/16" x 7-1/8" available upon request.
 c) Product Specification Level
 d) See engineering note titled "Expanding Gate Assembly Operation Explained" for details.
 e) Also referred to as "HANDWHEEL OPERATED"
 f) Ball Screw Operated (BSOP) - Manual gate valve with torque / turn reduction operator (15-1/2 turns, full open / closed). See engineering note titled "Ball Screw Operated (BSOP)" for details.
 g) Stuffing box can be repacked via injectable packing while the valve is in service up to the rated working pressure.
 h) Stuffing box can be repacked via back seat while the valve is in service up to the rated working pressure.
 i) Valve bonnet / ball screw housing (where applicable) equipped with grease port(s) and fitting(s) for bearing lubrication.



ENGINEERING NOTES

Expanding Gate Assembly Operation Explained – The expanding gate assembly consists of two main components; the gate (major) and the segment (minor). These components are assembled together using precision machined pins and high quality, precision formed and treated Nickel-Chromium alloy springs. When the valve is manually operated, the gate and segment act one against the other by means of a dual expanding wedge when the valve is either fully opened or fully closed. This expansion effect of the gate assembly against the valve seats, through parallel faces of the gate assembly, provides a strong and positive seal against pulsations and vibrations created by flow conditions.

Model FM4 and Model FM4 RC – These models are unidirectional gate valves equipped with an expanding gate assembly and a sealing seat in the downstream seat pocket. The upstream seat pocket is equipped with a non-sealing seat assembly. This allows pressure to bypass the upstream seat, equalize throughout the valve body, and only seal against the downstream seat assembly as the original Model M was intended. These models are marked with a flow direction arrow for accurate installation.

NOTE: When bidirectional operation is required, a slab gate valve is necessary. FM4 expanding gate valves (Model FM4 and Model FM4 RC) are not designed for bidirectional operation.

Pressure Testing – FM4 Series gate valves are not intended to be tested through the body lubrication fittings. These fittings are designed for lubrication purposes only. Shell tests and gate/seat tests shall be conducted from the end/outlet connection by qualified personnel.

Ball Screw Operated (BSOP) – FM4 Series gate valves are offered with an optional ball screw operator, which reduces the number of handwheel turns by approximately 60%, and greatly reduces the operating torque when opening and / or closing the valve. The number of turns required for a regular handwheel operated valve is between 39-1/4 to 39-1/2 from full open to full closed. The ball screw operated (BSOP) version of the same valve requires only 15-1/2 turns. This can be beneficial when time is of the essence.

TABLE 2 - TEMPERATURE RATINGS

TEMPERATURE CLASSIFICATION	OPERATING RANGE
K	-75°F (-60°C) TO 180°F (82°C)
L	-50°F (-46°C) TO 180°F (82°C)
N	-50°F (-46°C) TO 140°F (60°C)
P	-20°F (-29°C) TO 180°F (82°C)
S	0°F (-18°C) TO 140°F (60°C)
T	0°F (-18°C) TO 180°F (82°C)
U	0°F (-18°C) TO 250°F (121°C)
V	35°F (2°C) TO 250°F (121°C)

TABLE 3 - MATERIAL REQUIREMENTS

MATERIAL CLASS		MINIMUM MATERIAL REQUIREMENTS	
		BODY, BONNET, END & OUTLET CONNECTIONS	PRESSURE-CONTROLLING PARTS & STEMS
AA	GENERAL SERVICE	CARBON OR LOW-ALLOY STEEL	CARBON OR LOW-ALLOY STEEL
BB	GENERAL SERVICE	CARBON OR LOW-ALLOY STEEL	STAINLESS STEEL
CC	GENERAL SERVICE	STAINLESS STEEL	STAINLESS STEEL
DD	SOUR SERVICE ^a	CARBON OR LOW-ALLOY STEEL ^b	CARBON OR LOW-ALLOY STEEL ^b
EE	SOUR SERVICE ^a	CARBON OR LOW-ALLOY STEEL ^b	STAINLESS STEEL ^b
FF	SOUR SERVICE ^a	STAINLESS STEEL ^b	STAINLESS STEEL ^b
HH	SOUR SERVICE ^a	CRA ^{acd}	CRA ^{acd}

a) As defined by ISO 15156 (all parts) (NACE MR0175; See Clause 2).
 b) In accordance with ISO 15156 (NACE MR0175; See Clause 2).
 c) CRA required on retained-fluid wetted surfaces only.
 d) CRA as defined in Clause 3; ISO 15156 (all parts) (NACE MR0175; See Clause 2) definition of CRA does not apply.

VALVEWORKS USA DESCRIPTION KEY

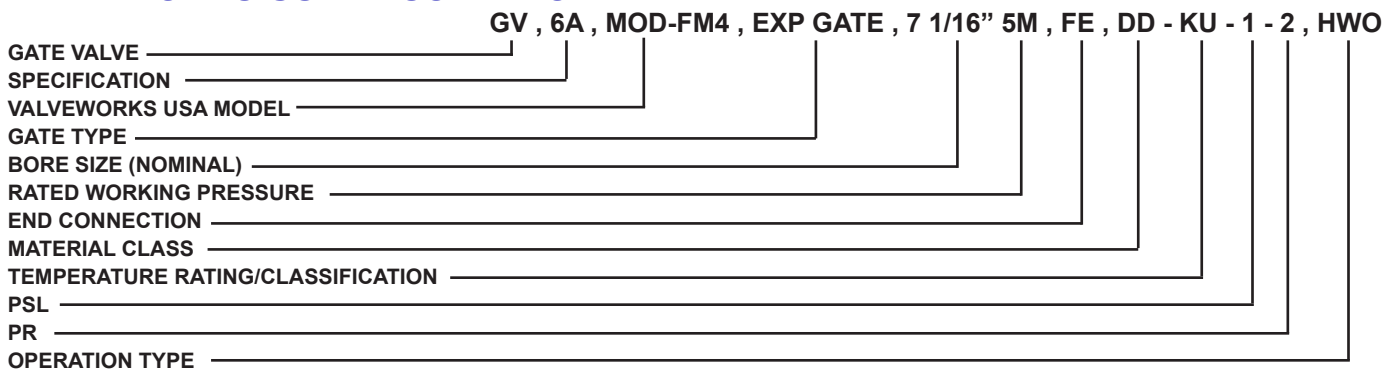

ABBREVIATION KEY

- | | | |
|---|-----------------------------------|-----------------------------------|
| FM4 = MODEL FM4 | HWO = HANDWHEEL OPERATED (MANUAL) | PSL = PRODUCT SPECIFICATION LEVEL |
| FM4 SG = MODEL FM4 SLAB GATE | BSOP = BALL-SCREW OPERATED | PR = PERFORMANCE REQUIREMENT |
| FM4 RC = MODEL FM4 ROUND CAVITY | EXP = EXPANDING GATE | CRA = CORROSION-RESISTANT ALLOY |
| FM4 RC SG = MODEL FM4 ROUND CAVITY SLAB GATE | SG = SLAB GATE | XYL = XYLAN® |
| FM4 BSOP = MODEL FM4 BALL-SCREW OPERATED | FE = FLANGED END | HF = HARDFACED |
| FM4 RC BSOP = MODEL FM4 ROUND CAVITY BALLSCREW OPERATED | RTJ = RING TYPE JOINT | |

HWO

BSOP

DIMENSION TABLE KEY

- A** FLANGE TO FLANGE
- B** VALVE BORE SIZE
- C** BORE CENTERLINE TO BOTTOM
- D** BORE CENTERLINE TO TOP
- E** HANDWHEEL DIAMETER
- NT** NUMBER OF TURNS
- RJ** RING JOINT
- BSS** BONNET STUD SIZE
- N** NUMBER OF STUDS
- WT** APPROXIMATE WEIGHT
- HT** HANDWHEEL OPERATING TORQUE

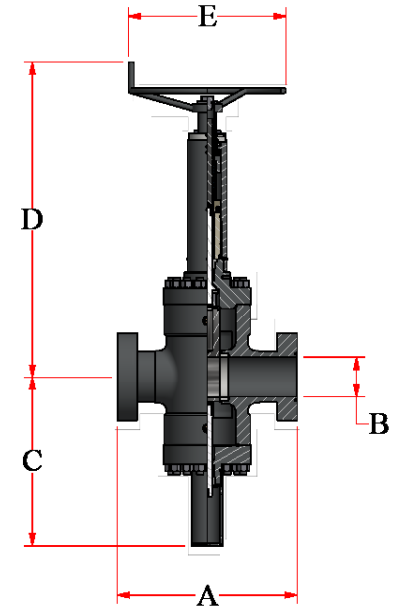
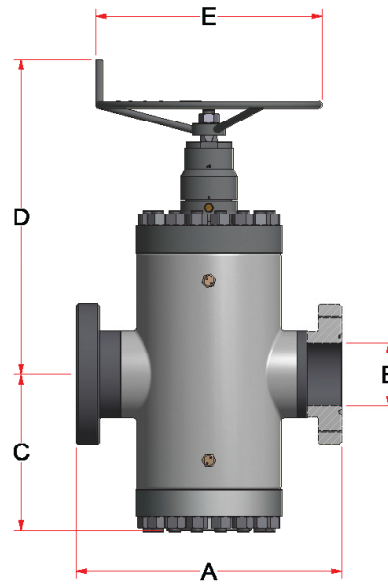

FLANGED GATE VALVES (HWO)

SIZE	WP (PSI)	A	B	C	D	E	NT	RJ	BSS	N	WT (LBS)	HT (FT-LBS)
7 1/16	2K	25 1/8	7 1/16	16 5/8	33 1/2	24	39 1/4	R-45	1 1/4	32	1047	356
7 1/16	3K	28 1/8	7 1/16	16 5/8	33 1/2	24	39 1/4	R-45	1 1/4	32	1550	500
7 1/16	5K	32	7 1/16	16 5/8	33 1/2	30	39 1/4	R-46	1 1/4	32	1650	783

FLANGED GATE VALVES (BSOP)

SIZE	WP (PSI)	A	B	C	D	E	NT	RJ	BSS	N	WT (LBS)	HT (FT-LBS)
7 1/16	3K	28 1/8	7 1/16	30 1/8	56	28	15 1/2	R-45	1 1/4	32	1915	152
7 1/16	5K	32	7 1/16	30 1/8	56	28	15 1/2	R-46	1 1/4	32	2015	253

*ALL DIMENSIONS ARE IN INCHES

ENGINEERED - DESIGNED - VERIFIED - QUALITY ASSURED - CERTIFIED - FIELD PROVEN - CREDIBLE - SUPPORTED

MODEL FM4 - UNIDIRECTIONAL, EXPANDING GATE, CAST BODY

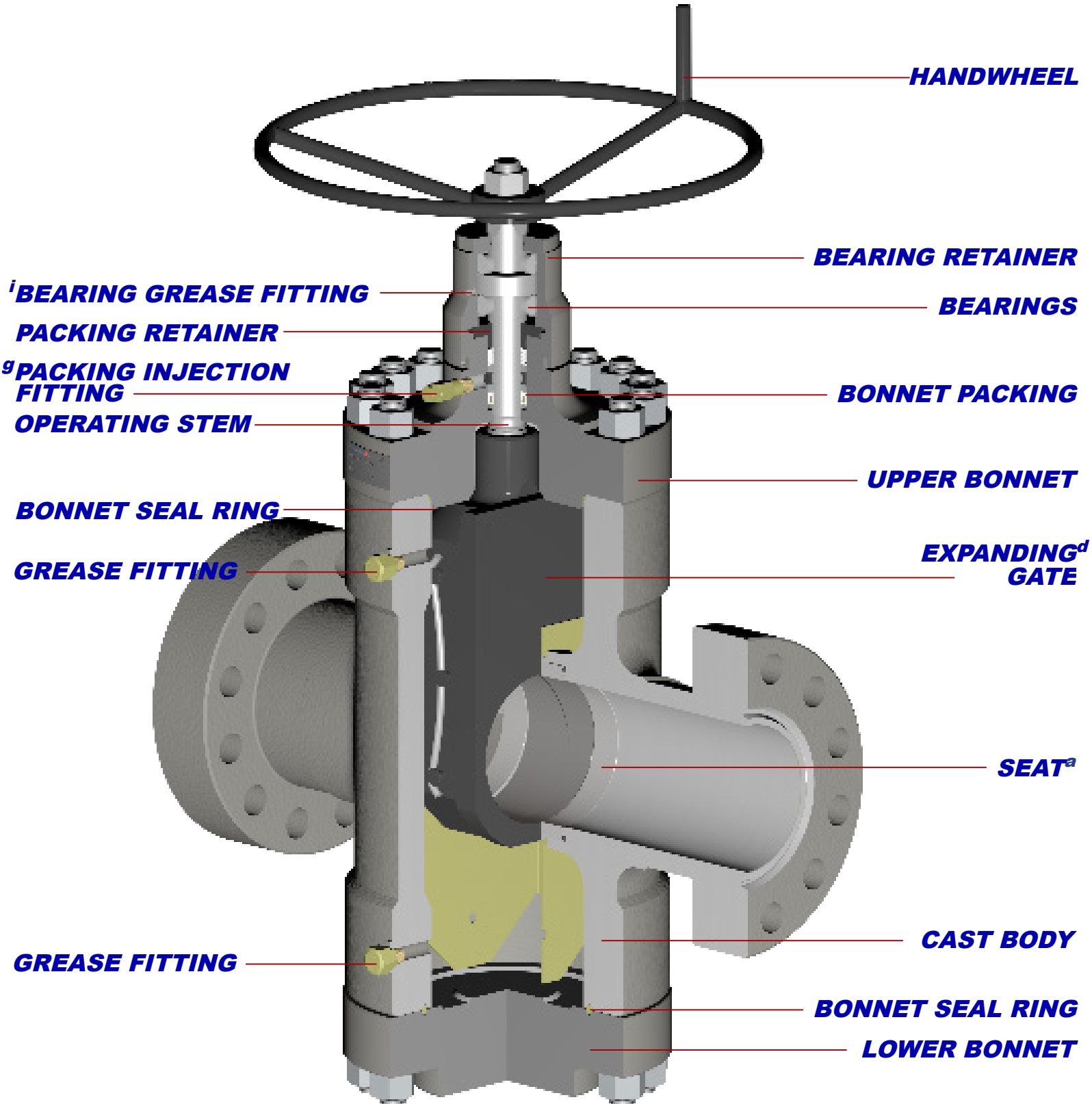

a) Equipped with a non-sealing seat on the upstream side. See engineering note titled "Model FM4 & Model FM4 RC" for details.

d) See engineering note titled "Expanding Gate Assembly Operation Explained" for details.

g) Stuffing box can be repacked via injectable packing while the valve is in service up to the rated working pressure.

i) Valve bonnet / ball screw housing (where applicable) equipped with grease port(s) and fitting(s) for bearing lubrication.

*THE ACTUAL PRODUCT MAY VARY SLIGHTLY FROM SHOWN SCHEMATIC DUE TO ENGINEERING APPROVED VARIATION

MODEL FM4 SG - BIDIRECTIONAL, SLAB GATE, CAST BODY

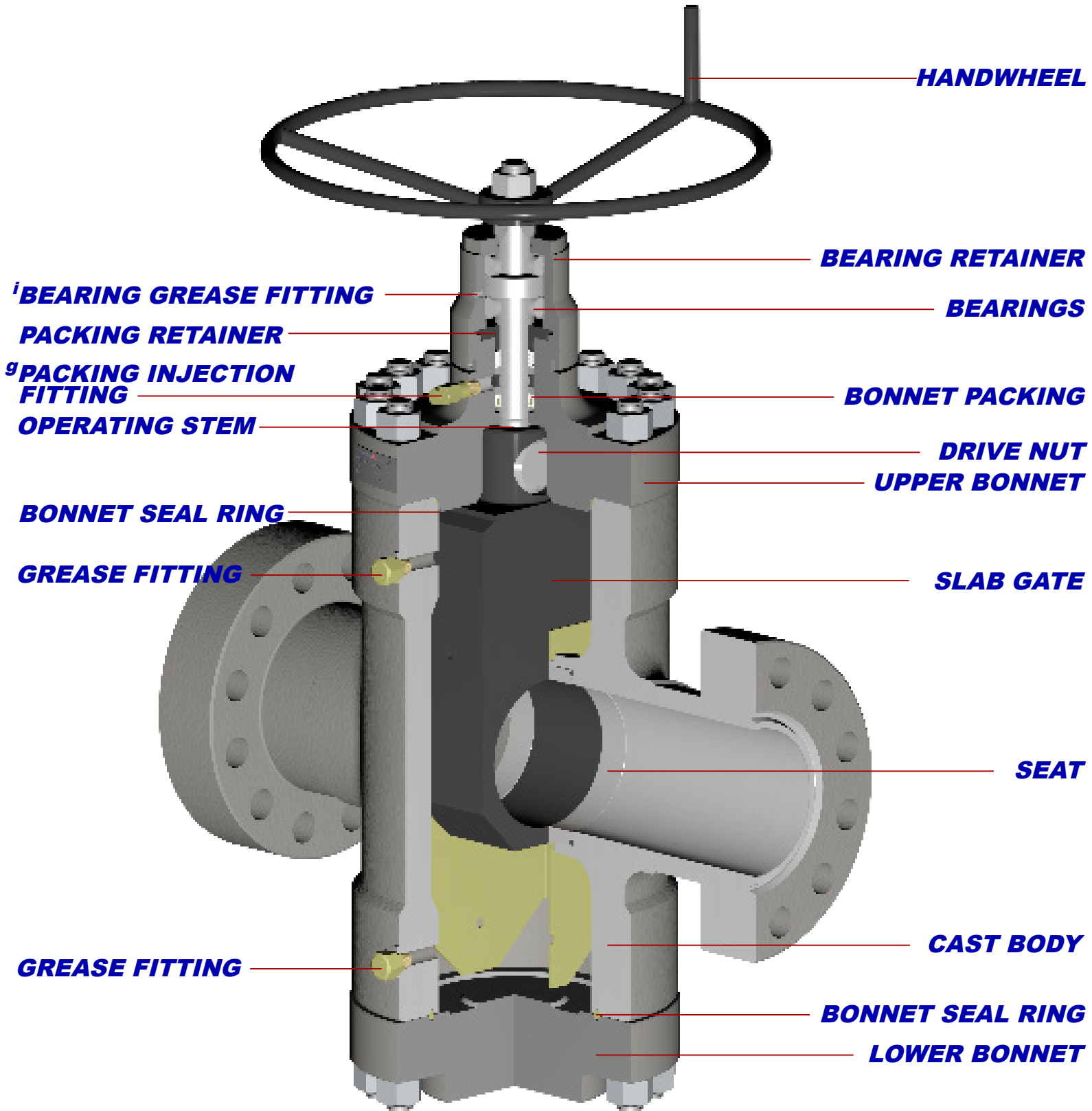

g) Stuffing box can be repacked via injectable packing while the valve is in service up to the rated working pressure.
i) Valve bonnet / ball screw housing (where applicable) equipped with grease port(s) and fitting(s) for bearing lubrication.

*THE ACTUAL PRODUCT MAY VARY SLIGHTLY FROM SHOWN SCHEMATIC DUE TO ENGINEERING APPROVED VARIATION

ENGINEERED - DESIGNED - VERIFIED - QUALITY ASSURED - CERTIFIED - FIELD PROVEN - CREDIBLE - SUPPORTED

MODEL FM4 RC - UNIDIRECTIONAL, EXPANDING GATE, FORGED BODY

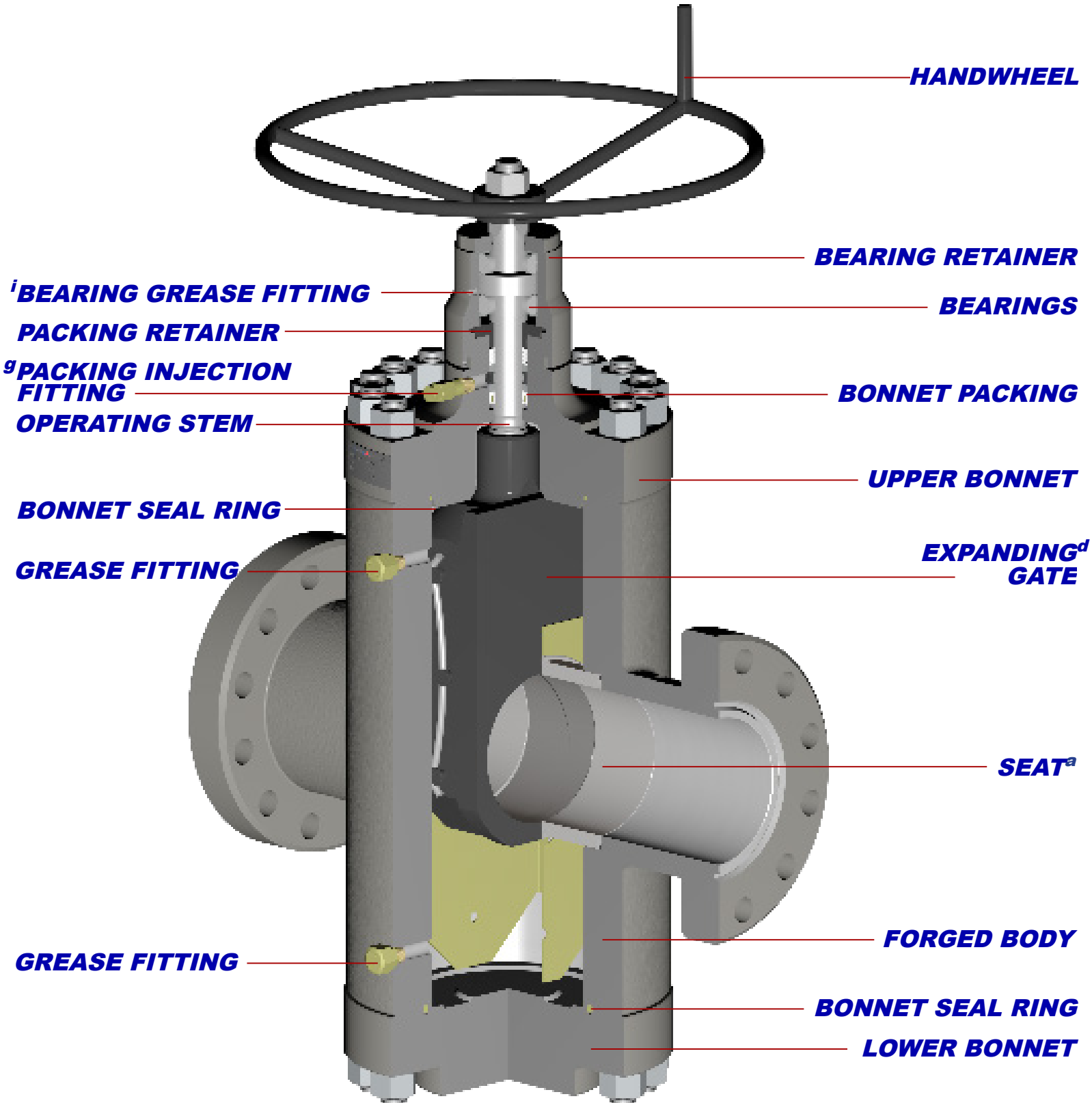

a) Equipped with a non-sealing seat on the upstream side. See engineering note titled "Model FM4 & Model FM4 RC" for details.

d) See engineering note titled "Expanding Gate Assembly Operation Explained" for details.

g) Stuffing box can be repacked via injectable packing while the valve is in service up to the rated working pressure.

i) Valve bonnet / ball screw housing (where applicable) equipped with grease port(s) and fitting(s) for bearing lubrication.

*THE ACTUAL PRODUCT MAY VARY SLIGHTLY FROM SHOWN SCHEMATIC DUE TO ENGINEERING APPROVED VARIATION

ENGINEERED - DESIGNED - VERIFIED - QUALITY ASSURED - CERTIFIED - FIELD PROVEN - CREDIBLE - SUPPORTED

MODEL FM4 RC SG - BIDIRECTIONAL, SLAB GATE, FORGED BODY

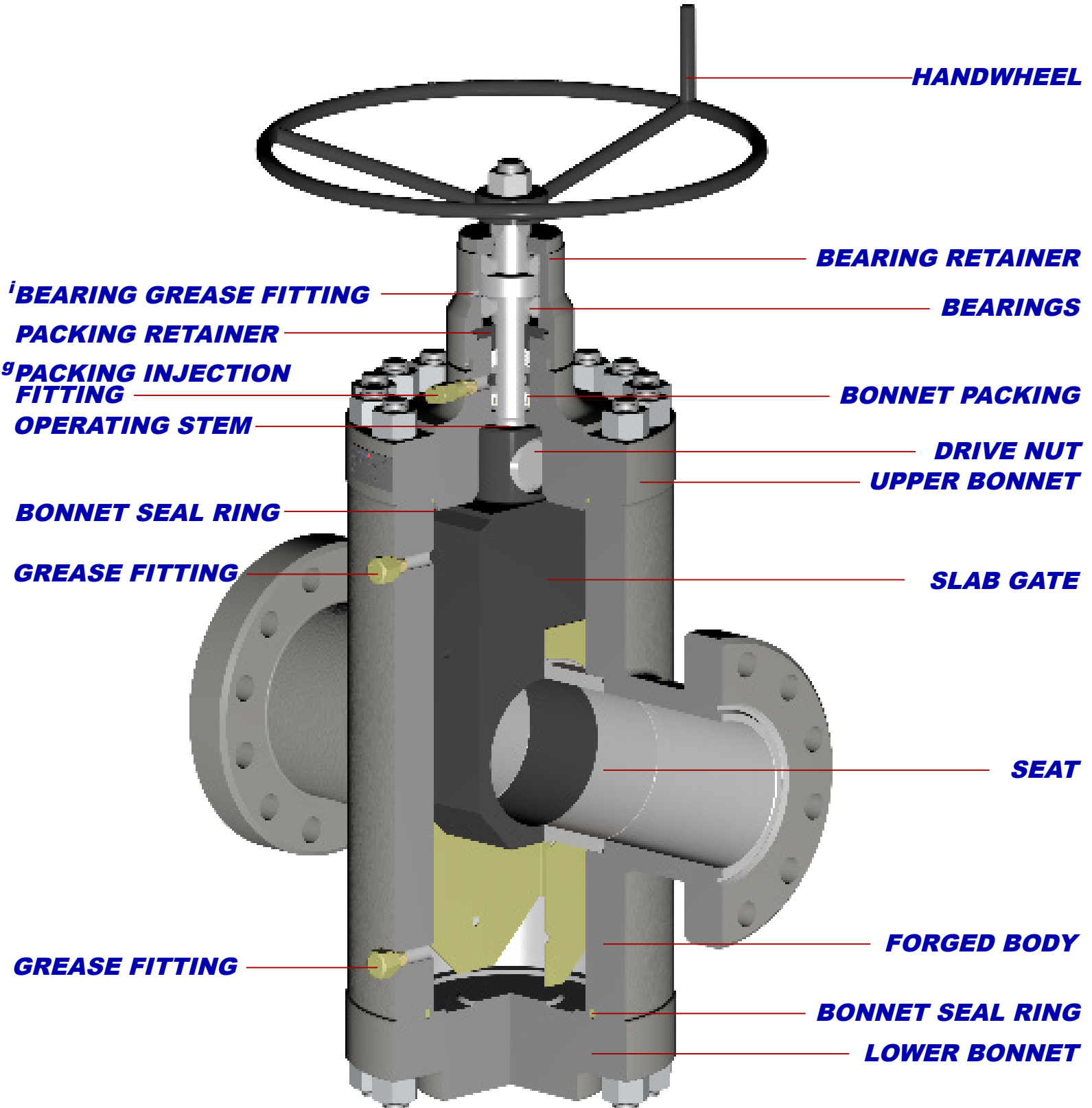

g) Stuffing box can be repacked via injectable packing while the valve is in service up to the rated working pressure.
i) Valve bonnet / ball screw housing (where applicable) equipped with grease port(s) and fitting(s) for bearing lubrication.

*THE ACTUAL PRODUCT MAY VARY SLIGHTLY FROM SHOWN SCHEMATIC DUE TO ENGINEERING APPROVED VARIATION

ENGINEERED - DESIGNED - VERIFIED - QUALITY ASSURED - CERTIFIED - FIELD PROVEN - CREDIBLE - SUPPORTED

MODEL FM4 BSOP - BIDIRECTIONAL, SLAB GATE, CAST BODY

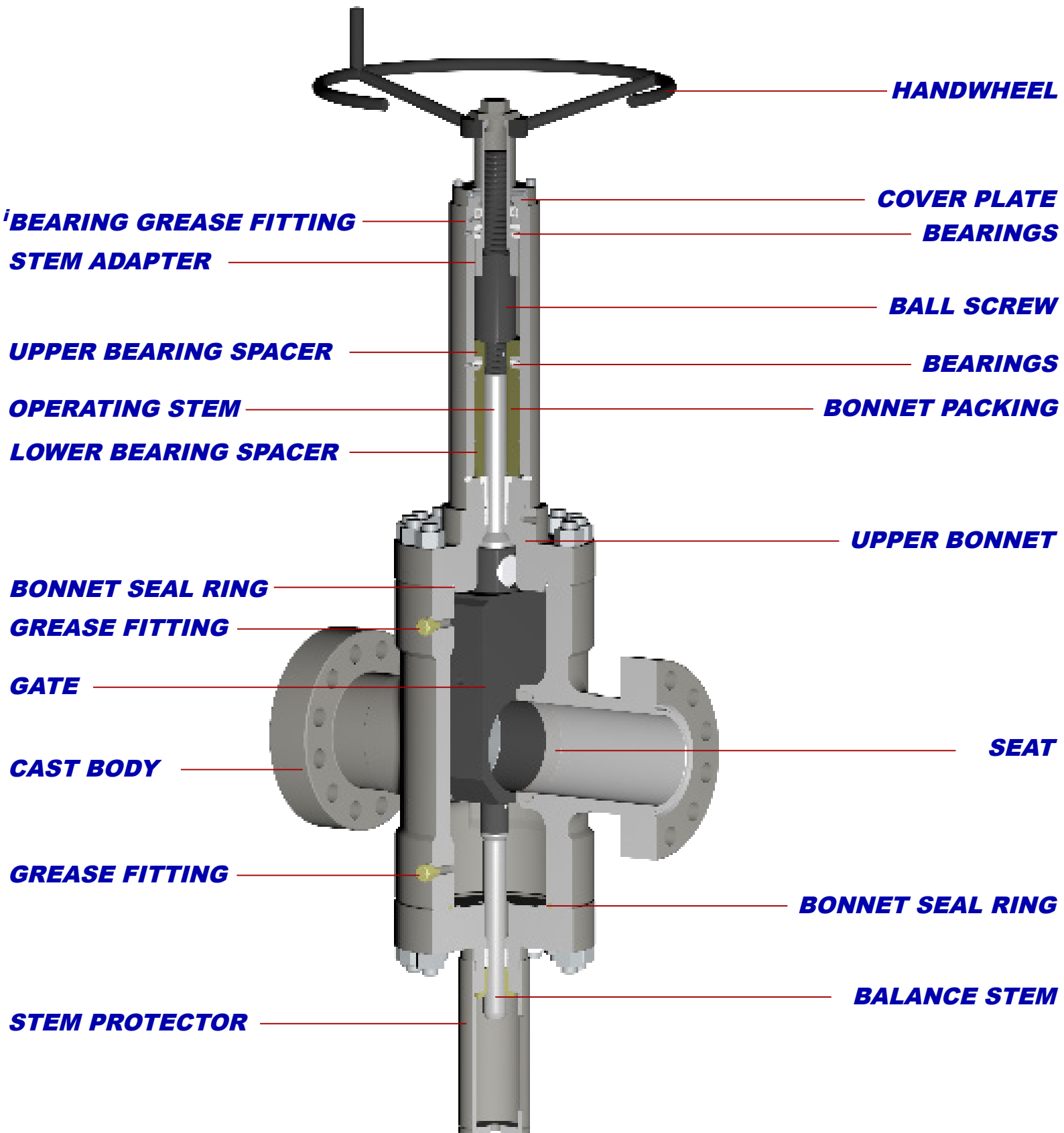

i) Valve bonnet / ball screw housing (where applicable) equipped with grease port(s) and fitting(s) for bearing lubrication

*THE ACTUAL PRODUCT MAY VARY SLIGHTLY FROM SHOWN SCHEMATIC DUE TO ENGINEERING APPROVED VARIATION

ENGINEERED - DESIGNED - VERIFIED - QUALITY ASSURED - CERTIFIED - FIELD PROVEN - CREDIBLE - SUPPORTED

MODEL FM4 RC BSOP - BIDIRECTIONAL, SLAB GATE, FORGED BODY

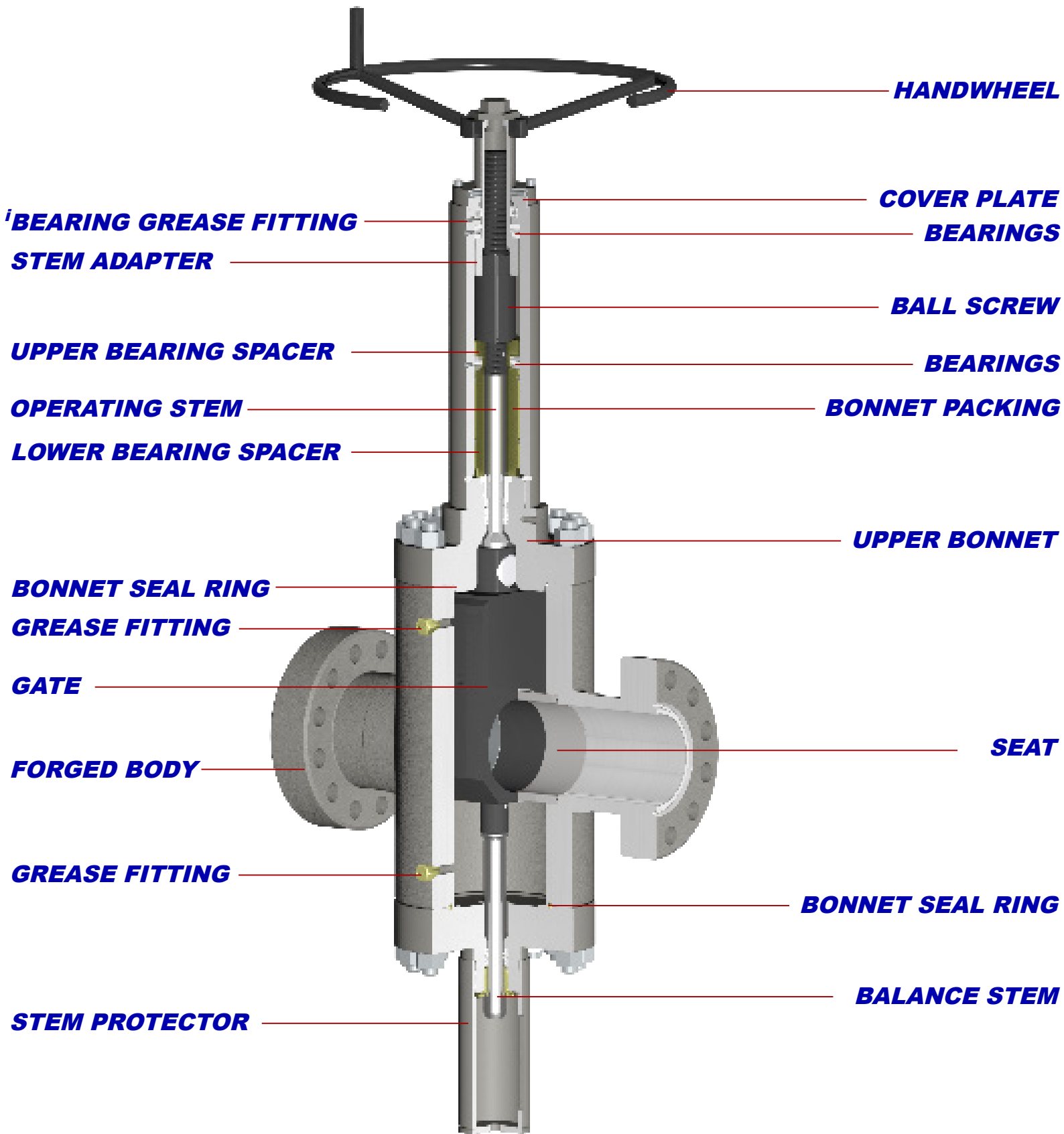

i) Valve bonnet / ball screw housing (where applicable) equipped with grease port(s) and fitting(s) for bearing lubrication

*THE ACTUAL PRODUCT MAY VARY SLIGHTLY FROM SHOWN SCHEMATIC DUE TO ENGINEERING APPROVED VARIATION

ENGINEERED - DESIGNED - VERIFIED - QUALITY ASSURED - CERTIFIED - FIELD PROVEN - CREDIBLE - SUPPORTED